

## Ductile Links in Quay Crane Tie-down Systems

Liftech Consultants Inc.  
October, 2006  
[www.liftech.net](http://www.liftech.net)



Recently, a number of cranes have collapsed due to severe wind loads.

The primary failure, induced by severe wind loads, has typically occurred in the wharf hardware. This is due to defective design, defective construction, or both.

This presentation discusses some tie-down design considerations and the ductile link; a mechanism to control the load distribution between multiple tie-downs.

## Multiple Tie-Downs

Tie-down forces are not evenly distributed to multiple tie-downs at a crane corner.



2 of 19

**Liftech**  
LIFTECH CONSULTANTS INC.

If there is more than one tie-down at a corner, the crane movement, combined with other factors, will cause one tie-down to carry significantly more than its share of the load. If the tie-down system is not ductile, it may fail before the load is shared by the other tie-downs. This will result in a progressive failure of the tie-downs and crane collapse.

The crane shown has four tie-downs at one corner. The tie-downs themselves are not ductile, but the wharf hardware is ductile.

Typically, the wharf hardware is designed by the civil engineer, and the crane designer may not be able to control the wharf hardware design. It is often necessary for the tie-down to be ductile.

Due to the potential uneven tie-down load distribution, it is advantageous to provide one large tie-down at a corner instead of multiple, smaller tie-downs. This is often not practical with large forces because connecting the tie-downs to the wharf hardware becomes too difficult to handle due to the weight of the tie-down components.

## Why Not?

Some reasons why forces are not evenly distributed:

Crane structure deformation

Tie-downs not vertical

Wharf pins not symmetric

Links not perfectly straight due to friction

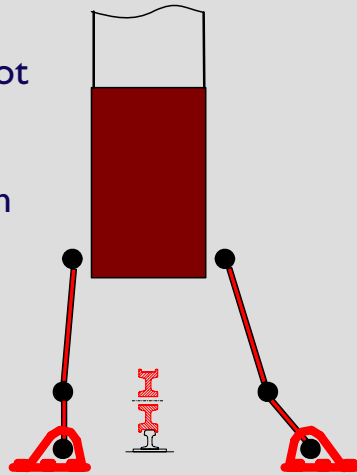

3 of 19

Liftech  
LIFE TECH CONSULTANTS INC.

Several factors cause unequal loading in multiple tie-downs at a corner.

If the tie-downs are not vertical, or if the tie-downs are asymmetric about the rail, loads will vary.

The initial tension in the tie-downs may vary, or the tension may not be sufficient to make the tie-down linkage perfectly straight.

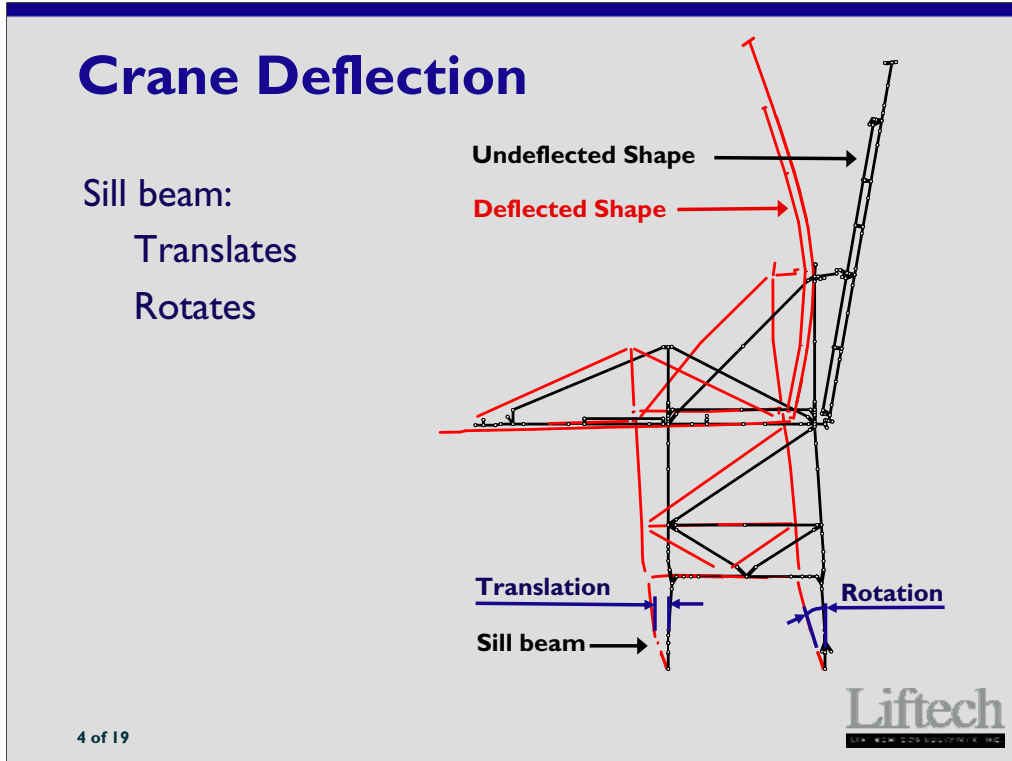

When a crane deforms, the sill beam translates and rotates.

Translation will result in unequal tie-down loads in asymmetric tie-downs.

Rotation will result in unequal tie-down loads in both asymmetric and symmetric tie-downs.

## Wheel Movement

Clearance between wheel flange and rail

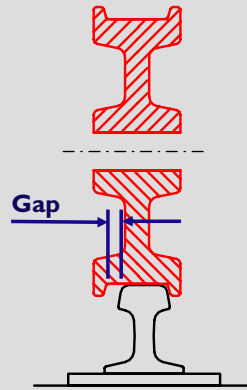

5 of 19

Liftech  
LIFTECH CONSULTANTS INC.

Normal wheel clearance adds to the relative motion between the crane and the wharf.

## Tie-down Loads

Due to the unequal load distribution, the tie-down wharf hardware design load is often less than the actual load.

This may result in progressive failure:

Wharf elements are often brittle, e.g.  
anchorage failures

Brittle elements fail before loads can  
redistribute

In some cases, one tie-down at a corner may fail before the load is distributed to other tie-downs. The failure may be in the crane hardware or the wharf hardware.

## **Goal: Develop Forgiving System**

Two equalization approaches

Mechanical equalizer – equalizer beam

Ductile link – equalization through ductile yielding of a structural element

7 of 19

**Liftech**  
LIFTECH CONSULTANTS INC.

The full strength of all the tie-downs in the crane corners may be utilized if the tie-down loads are mechanically equalized or if the tie-down system is capable of deforming plastically without losing strength; that is, if the system is ductile.

Mechanical equalization is usually cumbersome, expensive, and impractical. A ductile system can be practical and economic. The ductile element may be in the wharf hardware or in the tie-downs. The use of ductile links also requires smaller turnbuckles and wharf hardware, compared to conventional tie-down systems.

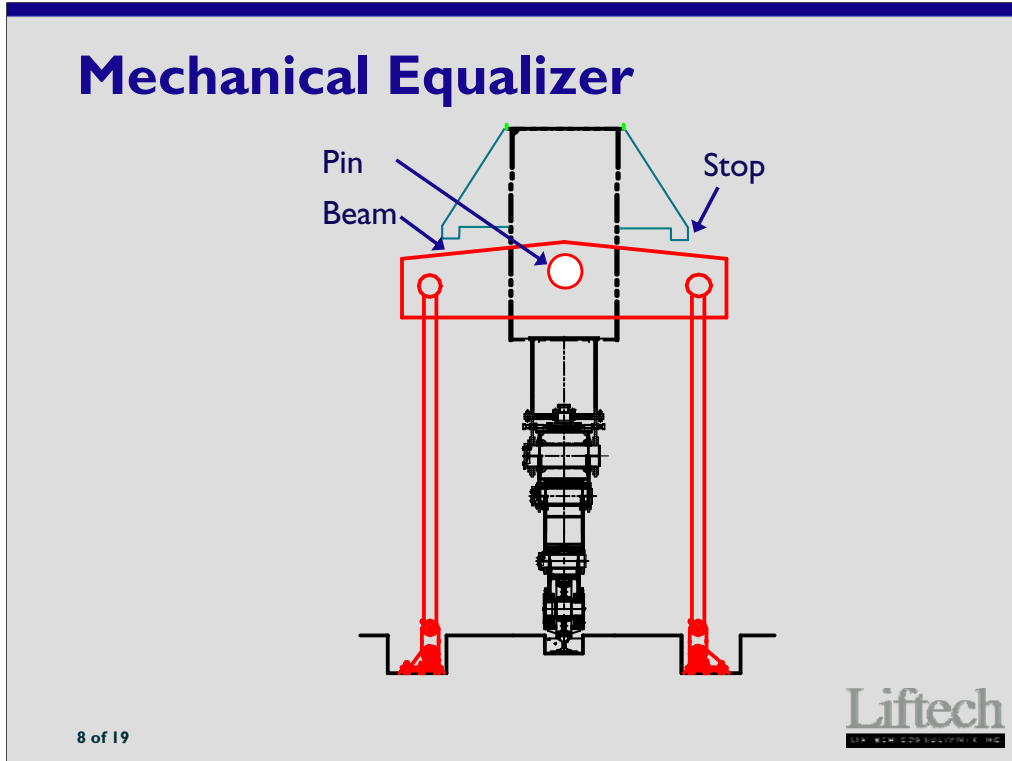

The simplest mechanical equalizer is an equalizer beam. If used, the system should include a stop, ensuring that if one tie-down fails, the other may still carry some load.

Sometimes, the equalizer system includes a number of links. These are usually difficult to work with and may be very sensitive to small crane displacements.

## **Mechanical Equalizer Problems**

Massive equalizer beam for typhoon conditions

Difficult to retrofit old cranes

Tie-downs must be vertical

9 of 19

**Liftech**  
LIFTECH CONSULTANTS INC.

If the tie-downs are not vertical, small crane displacements may cause a large imbalance in the tie-down forces.

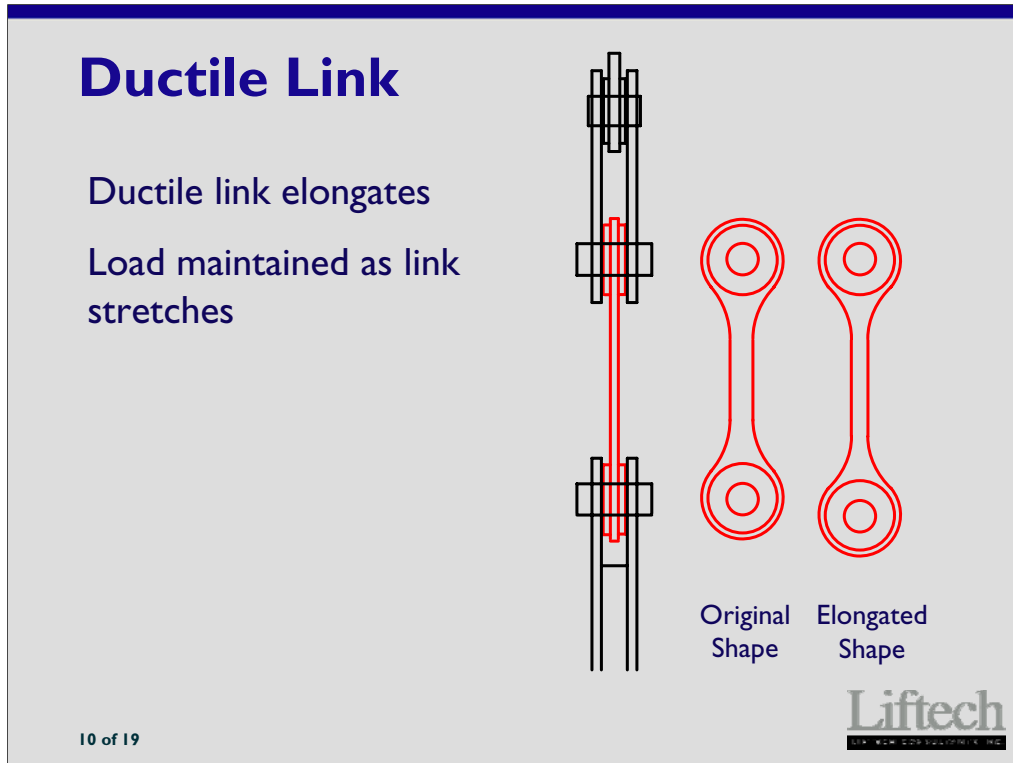

If one ductile link in the tie-down system is capable of deforming plastically without loss of strength until the other link engages, the tie-down loads will eventually equalize.

Plastic elements acting as fuses have been used for decades to protect structures from severe damage during earthquakes. The ductile link can be designed using well developed engineering principles.

An outline of the design considerations is provided later in this presentation.

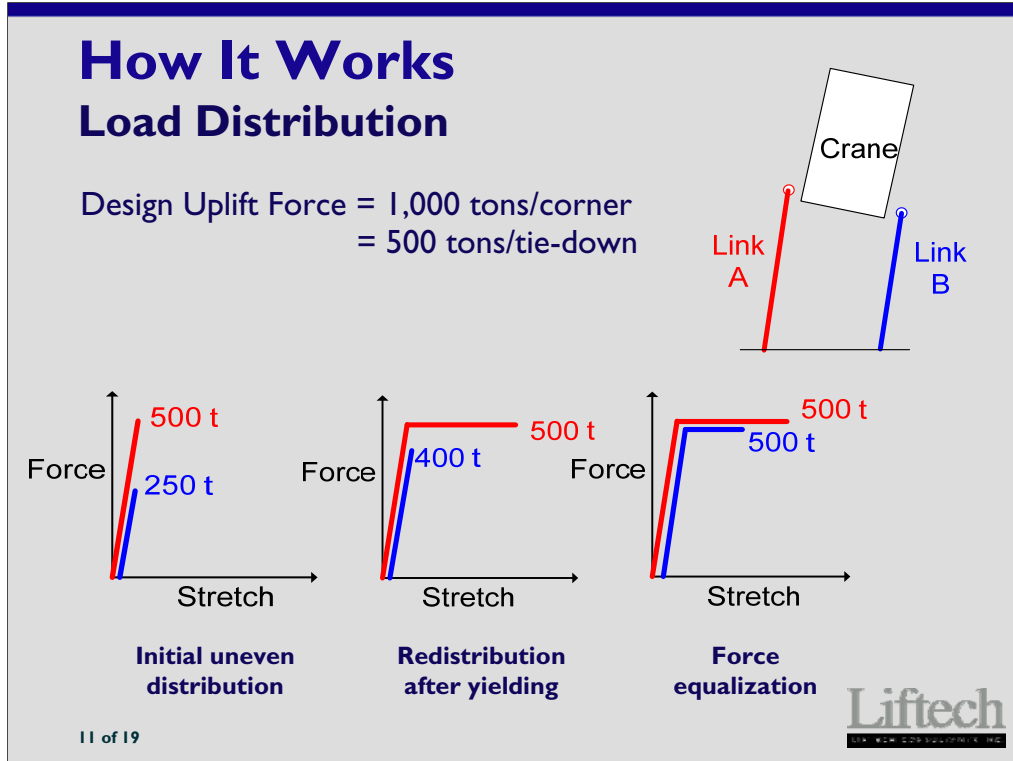

Initially the loads in multiple tie-downs are not equal. In some cases, the entire corner upload force is carried to one tie-down. In this example, the initial distribution is uneven. The desired distribution is 50% and 50%.

With the ductile link, the heavily loaded tie-down yields, allowing more load to transfer to the lightly loaded tie-down.

As the uplift force increases, the ductile link stretches plastically. The load remains constant in the heavily loaded tie-down and increases in the lightly loaded tie-down.

Eventually the load is shared equally, and the full strength of the multiple tie-downs is utilized, as intended.

## Features

Ductile links are small and inexpensive

Normal steel

Easy to fabricate

Smaller turnbuckles

Easy to retrofit most existing turnbuckle systems

**Improves reliability of the system**



12 of 19

**Liftech**  
LIFTECH CONSULTANTS INC.

Ductile links improve reliability.

Ductile links can be added to existing cranes.

On new cranes with multiple tie-downs, using ductile links allows for smaller turnbuckles and wharf hardware.

## Requirement

Replace link after significant stretch has occurred to ensure proper performance in the next typhoon.

Original Shape    Elongated Shape

**Liftech**  
CONSULTANTS INC.

13 of 19

To ensure that adequate ductility exists and that the ductile link will equalize the loads in the next typhoon, the link should be replaced if significant stretch has occurred.

Typical replacement design intervals will be decades.

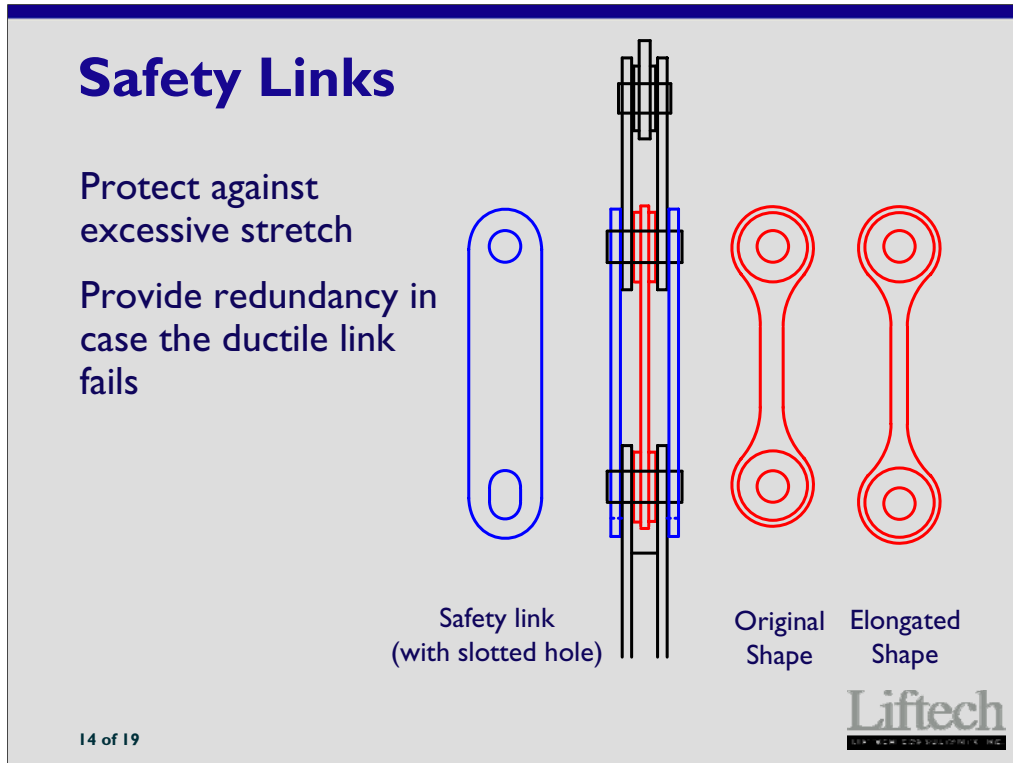

Finally, one more issue needs consideration. What if both links are loaded to their failure deformation, but their strength is not sufficient to carry the load? How can we ensure that failure will not occur until the other elements are fully utilized?

It is likely that the elements in the rest of the system have some reserve strength. This strength can be utilized with the use of safety links connected in parallel with the ductile link. The ductile link has done its job and distributed the load. Now the failure should be controlled by the remaining weakest element.

The safety links provide a mechanism that ensures failure will not occur until the full strength of the system is developed. The safety link also provides some redundancy in case of failure in the ductile link.

## Ductile Link Design

- 1 Calculate the forces and displacements due to the factored dead load and storm wind load.
- 2 Calculate the average tie-down force at each corner, i.e. the total corner force divided by the number of tie-downs at the corner.
- 3 Design the ductile link breaking strength for the calculated average tie-down uplift force.

<next>

15 of 19

**Liftech**  
LIFTECH CONSULTANTS INC.

The details of the system are important.

The design steps provided are only guidelines and only mention a few of the design issues.

## **Ductile Link Design (cont'd)**

- 4 Verify that the strengths of the other tie-down components, including the wharf hardware, exceed the link breaking strength.
- 5 Design the ductile link based on test samples of the actual link material. Verify that the link is ductile enough to accommodate the required plastic deformation.
- 6 Design the safety links to develop 120% of the strength of the weakest element in the tie-down system, not including the ductile link.

# Example: Ductile Link

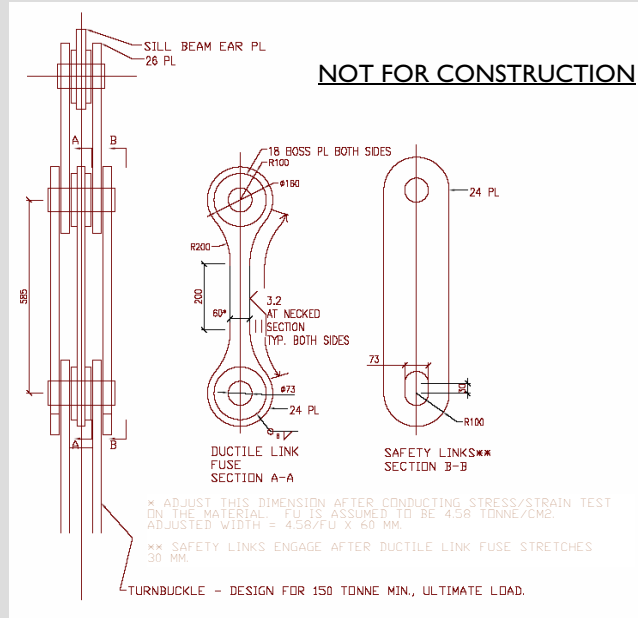

NOT FOR CONSTRUCTION

## Ductile Links in Quay Crane Tie-down Systems

Liftech Consultants Inc.

October, 2006

[www.liftech.net](http://www.liftech.net)

**Thank you**



# Ductile Link

October 2006

Liftech Consultants Inc.

**Copyright 2006 by Liftech Consultants Inc. All rights reserved.**

The information included in this presentation may not be altered, copied, or used without written authorization from Liftech Consultants Inc. Anyone making use of the information assumes all liability arising from such use.

**Quality Assurance Review:**

Date: December 9, 2005  
Author: Patrick McCarthy, Erik Soderberg  
Editor: Mike Jordan  
Principal: Erik Soderberg

**Revisions:**

Rev #	By	Date	Editor	Description
1	PWM	10-13-06	JKH	Changed slide 17 from Fy to Fu & minor changes to slide notes throughout.

N:\Papers & Presentations\Working\ACT FV Presentation\_2006-October\06 Crane Procurement\06 Ductile Link\_01\_pwm.ppt