

## **Seismic Response of Jumbo Container Cranes and Design Recommendations to Limit Damage and Prevent Collapse**

Erik Soderberg<sup>1</sup> and Michael Jordan<sup>2</sup>

<sup>1</sup> Erik Soderberg, SE, Principal, Liftech Consultants Inc., 344 20<sup>th</sup> Street, Suite 360, Oakland, CA 94612; Tel 510-832-5606, Fax 510-832-2436; esoderberg@liftech.net

<sup>2</sup> Michael Jordan, SE, CEO, Liftech Consultants Inc.; mjordan@liftech.net

### **Introduction**

Container cranes have evolved to serve ever increasing ship sizes. Today's typical container cranes are about triple the size of the first cranes, much heavier, and more vulnerable to damage from seismic events.

The seismic vulnerability of these large cranes was only recently recognized as a result of detailed time history analysis. This paper discusses what changed to cause the vulnerability, the results of the time history analysis, a physical explanation of the crane-wharf interaction, the inconsistency of seismic design criteria for wharves and cranes, recommended design criteria, and some base isolation and modification concepts.

### **What has changed?**

The first dockside container crane, designed and built by Paceco for Matson Navigation Co in 1959, had a 33' rail gage and weighed less than 1000 k. In the 1960's similar, yet larger, cranes were built with 50' rail gages. In the 1970's cranes with 100' rail gages and 135' outreach were built to serve the first Post-Panamax vessels. Beginning in the 1990's and continuing today, much larger and heavier cranes are being built to service vessels carrying 22 or more containers across the ship deck.

Cranes in high wind regions require tie-downs to fasten the crane to the wharf. Since tie-downs are only engaged when high winds are expected, cranes are usually not connected to the wharf and can lift from the rail. The crane's response in a

seismic event is interrupted when the crane's legs lift off the rail. Thus, the lateral load caused by a seismic event is limited to the tipping force.

Figure 1 shows a typical 50'-gauge Panamax crane from the 1960's and a recent 100'-gauge jumbo crane. Notice that the inertia load to tip the 50'-gauge crane is about 0.3 g and 300 kips, and the load to tip the 100'-gauge crane is approximately 0.5 g., or almost 1500 kips. When cranes tip, all loads are carried by two legs. Also notice the portal height is greater on the 100'-gauge crane. The moment at the top of the portal leg, where structural failure is most likely to occur, equals the lateral force times the height. The moment in the 100'-gauge crane leg is significantly greater than that in the 50' crane, and is much larger relative to the moment due to all other load combinations.

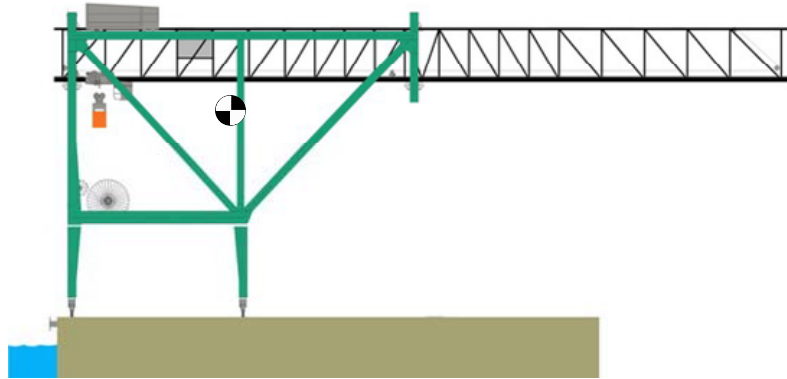


**Figure 1. Small crane and jumbo crane tipping forces**

For older cranes, the difference in moment due to the seismic load and the other loads wasn't as significant; even if the crane wasn't designed for the tipping load, its structure usually had the required strength and ductility necessary to keep it from collapsing in a major earthquake. The jumbo cranes, however, with greater difference in loads must be designed for a seismic loading or these cranes may collapse before tipping.

### **Time History Analysis**

Since the center of gravity (cg) of a conventional A-frame crane is nearly centered between the crane rails, lateral seismic forces can lift the crane off the rail a reasonable amount without becoming unstable. This is not true for low profile cranes. The cg of low profile cranes with the boom stowed is nearly over the landside gantry rail. See Figure 2. A small lift of the waterside legs can cause the crane to topple.



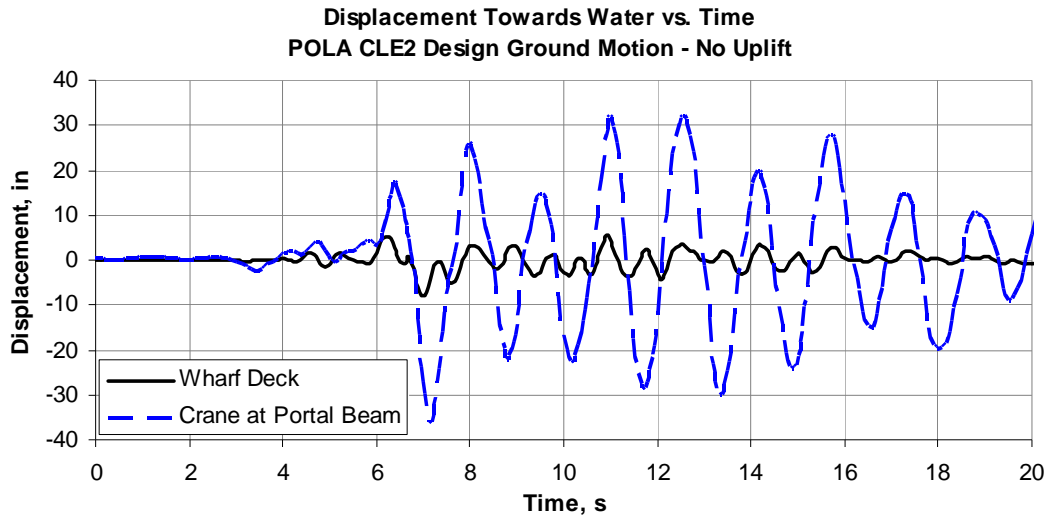
**Figure 2. Low profile crane cg**

To investigate the feasibility of using low profile cranes in a high seismic zone, a time history analysis was performed to investigate the response of a low profile crane. The response of conventional A-frame cranes was also investigated. These investigations led to the surprising discovery that both the low profile and the conventional cranes are vulnerable to collapse during a seismic event.

Previously, crane response was investigated only to determine the effect of the crane on the wharf. Because of differences in the dynamic characteristics of the wharf and crane, the crane reduces the wharf displacement. See Figure 3. During an earthquake, initially the crane moves very little as the wharf moves underneath it. The crane, with a longer period, stays nearly at rest for a few seconds. As the wharf moves, the crane reacts against the wharf's motion and reduces the forces on the supporting piles. The studies confirm that the crane reduces the wharf seismic forces.

But what happens to the crane? The crane displacement in the direction of trolley travel typically peaks after 10 seconds of initial ground movement. The jumbo crane may sway up to 30 inches at the portal tie level. The problem for the typical crane is inadequate strength and ductility at the top of the portal frame legs.

The lateral resisting frame parallel to the gantry rails is a flexible "O-frame", and the tipping force in this direction is typically lower, so the seismic design forces in the direction of gantry travel do not cause significant stresses.



**Figure 3. Crane and wharf seismic response**

### Seismic Criteria—Wharf vs. Crane

Wharf design and crane design criteria have been inconsistent. Wharves are sometimes designed for three levels of earthquake, with different levels of damage allowed for each level of earthquake. Wharf design criteria currently being discussed by the ASCE COPRI Seismic Design Guidelines for Piers and Wharves are shown in Table 1.

**Table 1: Recent Wharf Design Criteria**

<b>Earthquake Level</b>	<b>Chance of Occurrence</b>	<b>Mean Recurrence Interval (MRI)</b>	<b>Level of damage</b>
OLE Operational Level Earthquake	50% in 50 years	72 years	Minor damage, remain near operational
CLE Contingency Level Earthquake	10% in 50 years	475	Major damage, repairable, no collapse
ULE Ultimate Level Earthquake	5% in 50 years	975	No collapse

The typical crane design criterion is: Crane 0.20 g lateral– minor damage.

Some cranes designed to this wharf criteria will sustain more than minor damage during an OLE, and some will even collapse during a CLE or ULE. It is an incorrect assumption on the part of many stakeholders (operators, owners, shippers)

that the wharf and cranes will be operational or repairable after a seismic event. The fact is that although the wharf may be operational, the crane may be unstable and completely unusable.

There is a solution to this predicament. New cranes can be designed to meet the wharf criteria with only a small cost increase, and existing cranes can be assessed and retrofitted, if necessary, just as existing buildings are retrofitted.

## Recommendations

### *Approaches for New Cranes*

There are three approaches for new crane design:

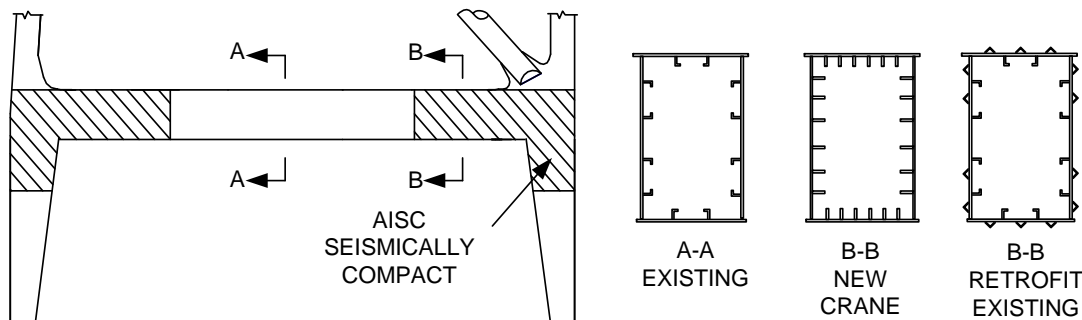
#### *Force based*

Increase the crane strength so the crane legs are capable of resisting the tipping loads, i.e. the legs do not fail when a lateral force, large enough to tip the crane about the rails is applied. Forced based criteria are not appropriate for low-profile cranes and may be impractical for some jumbo cranes.

#### *Displacement based*

Design the lateral force resisting components to deform enough to accept significant displacements, typically 30 inches each way at the portal beam, without exceeding specified strain limits.

Those components with stresses more than 0.80 times the yield stress should be compact and comply with the *AISC Seismic Design Manual* requirements for special moment frames. For a typical container crane this is at and near the portal-to-leg joint. There is no advantage in making the entire frame meet the AISC special moment frame criteria. See Figure 4.



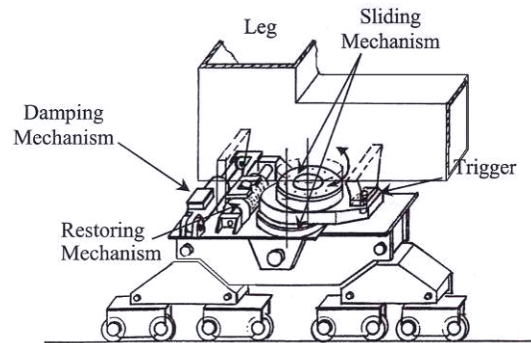
**Figure 4. Seismic compactness locations and requirements**

The strains due to forces in orthogonal directions should be combined by adding 30 percent of those for one direction with 100 percent of those in the other. In addition, the design should be verified using collapse mechanism analysis (also called “pushover analysis”), including P-delta effects and nonlinear yielding.

*Base Isolation:*

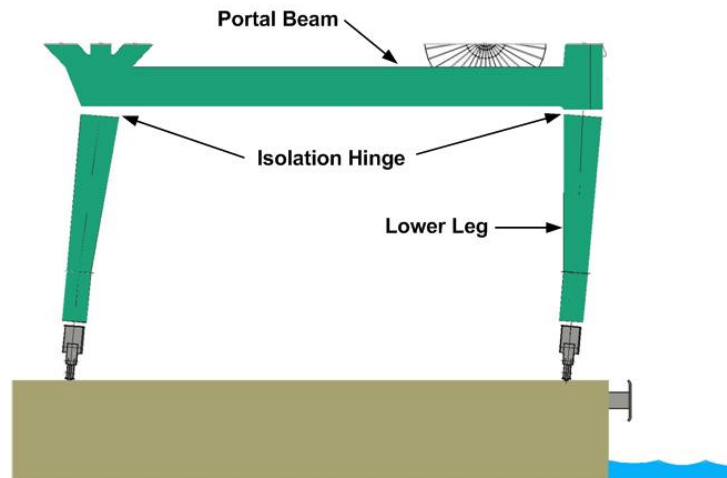
Provide base isolation devices designed using time history analysis. The required displacement will be about 30 inches. The base isolation system should not effect normal operations. It should be automatic and able to be easily restored to the initial conditions.

Currently, there are several base isolation systems in development or use. Mitsubishi Heavy Industries has developed a base isolation system that isolates the crane at the sill beam, shown in Figure 5. This system requires a damping mechanism, a sliding mechanism, a trigger, and a restoring mechanism.

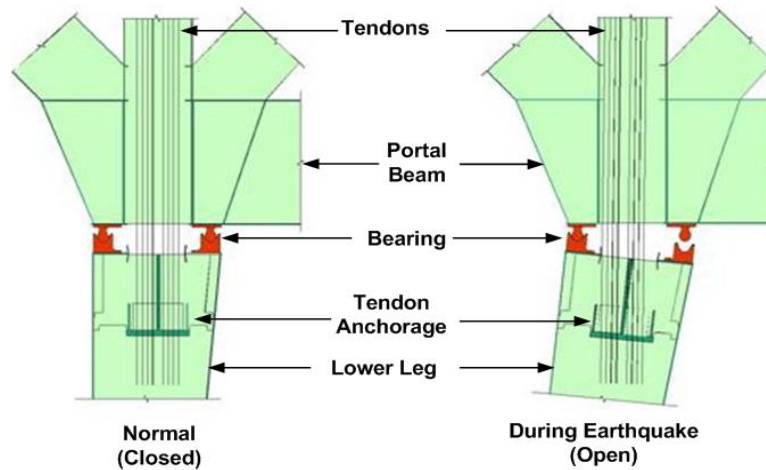


**Figure 5. MHI isolation system**

Figure 6 shows an isolation system developed by Liftech that isolates the crane at the top of portal legs, is automatic and does not require mechanisms other than the isolation mechanism. It is self-restoring and no damage is caused by the design earthquake. The system uses hardware common to bridge construction. Figure 7 provides a detail of the isolation hinge.



**Figure 6. Liftech isolation system—Arrangement**



**Figure 7. Liftech isolation system—Isolation hinge**

### *Approaches for Existing Cranes*

#### *Determine Vulnerability*

The analysis of the crane frame to check for seismic vulnerability does not require any special knowledge of cranes. Typically, the main difference between building frames and crane frames is that the local plate width-to-thickness ratios are greater for cranes. The specifications from the *AISC Steel Construction Manual*, section E7, provide methods for analyzing thin stiffened plates. Ultimate strength methods are discussed in the *Guide to Stability Design Criteria for Metal Structures* (Galambos 1988).

It is only necessary to check the lateral force resisting components of the crane frame using the criteria suggested above for new cranes. Less stringent criteria may be justified for existing cranes. If the criteria are not met, the appropriate action will depend on the consequences of failure. Usually the cost to avoid permanent deformation will not be justified.

If strengthening is justified, perform a pushover analysis. Use an ultimate strength approach, e.g. effective width, for local buckling.

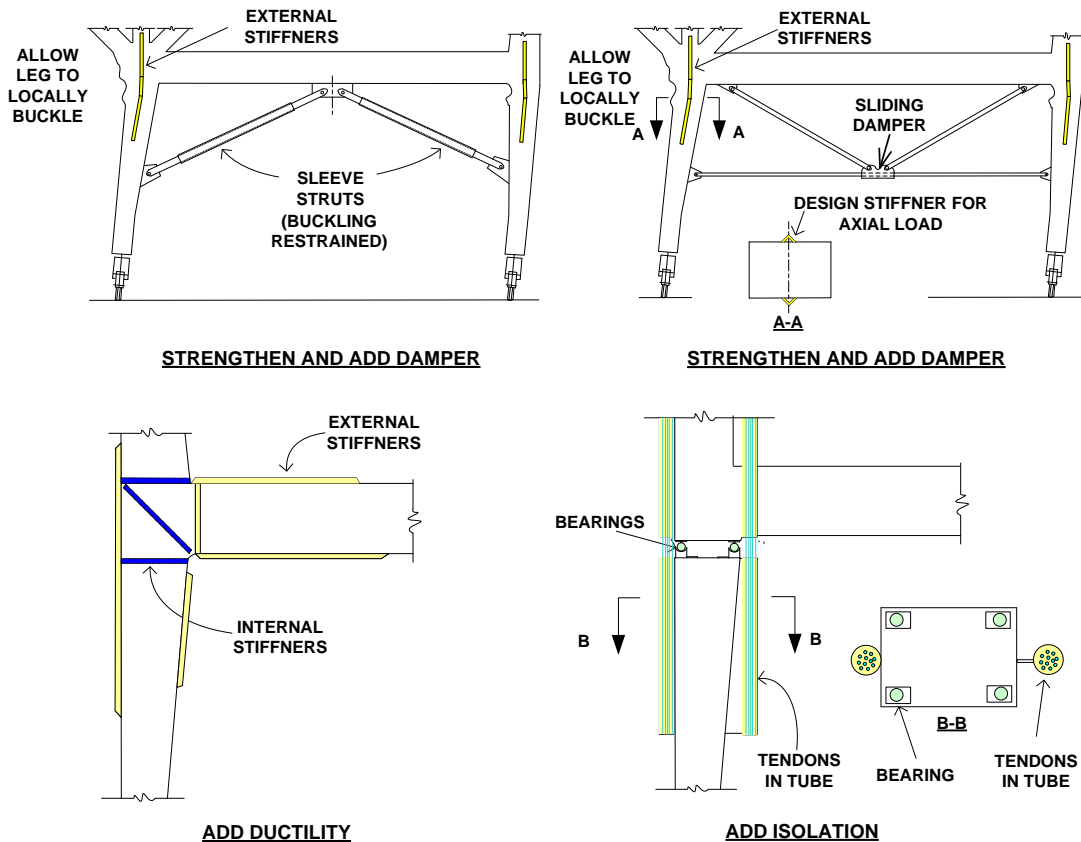
#### *Determine Retrofit Options*

Options for retrofit include strengthening the crane portal structure, stiffening the crane at specific locations to increase the ductility of the structure, or adding an isolation mechanism. Strengthening the crane may be practical if the clearance under the portal can be decreased. If more ductility is needed, stiffeners may need to be added to the legs and portal beams near the portal-leg joint and within the joint. These regions are cross hatched in Figure 4 above. Adding an isolation mechanism

may be practical if the crane is also being raised. Table 2 summarizes the retrofit options. Some retrofit options are provided in Figure 8

**Table 2: Retrofit Options**

Option	Pro	Con	Comment
Strengthen structure	The maximum acceleration that causes damage is increased.	Costly	Less costly if the clearance under portal can be decreased.
Improve ductility by adding stiffeners	Least Costly. Avoids collapse.	Acceleration at which damage occurs is not increased.	
Add isolation mechanism	No damage	May be expensive	Less expensive if added with crane raise modification.



**Figure 8. Retrofit concepts**

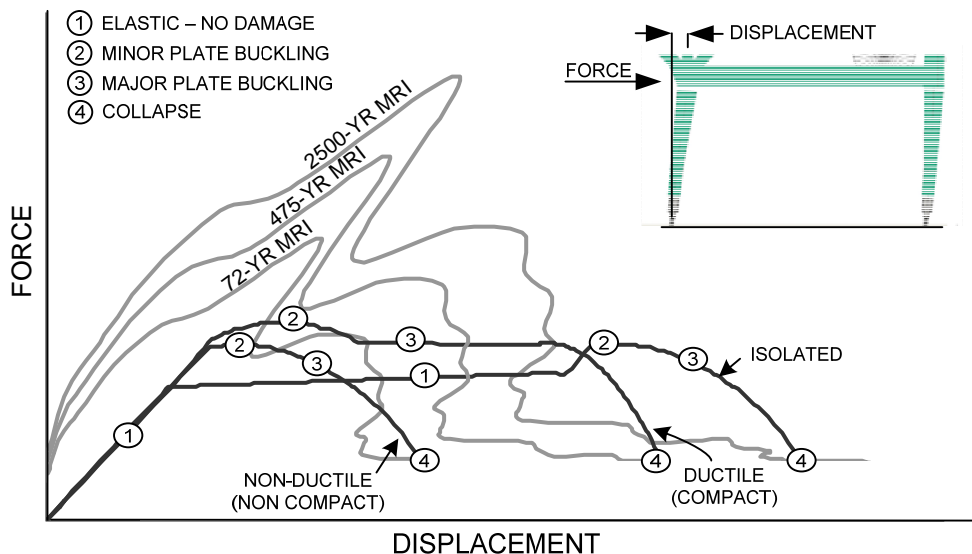
## Cost-Benefit Analysis

Determine the costs of retrofitting the crane to different levels of earthquakes, and compare the costs to the expected damage. Expected damage should include repairs, lost income, and disruption. Some users may find it most economic to strengthen a suitable number of cranes to stay operational after a major event, and accept serious damage and collapse of other cranes.

## Expected Performance

A hypothetical pushover diagram showing the idealized performance for non-ductile, ductile, and isolated crane structures is shown in Figure 9. The initial stiffness and acceleration at which yielding and buckling occur will vary depending on the crane and design criteria. The crane with seismically compact sections will tolerate greater deformations than a crane having less compact sections. For some isolation schemes, it is practical to design for the required displacement from a seismic event having a 2500-year mean recurrence interval (MRI).

The demand curves shown, those labeled MRI, are the averages for several design time histories for a single degree of freedom structure on a typical wharf in a region of high seismicity. A constant damping ratio was used for simplification. Increased damping resulting from plate yielding and buckling will result in a smaller displacement demand for both the non-ductile and ductile schemes.



**Figure 9. Pushover curve—Non-Ductile, ductile, and isolated portal frame**

As shown in the pushover curve, the required displacement reaches a limit as the portion of the crane above the isolation mechanism, or yield location “hinge” under the portal beam, displaces with the wharf. This limit is approximately 30 inches for the cranes studied with 475-MRI design time histories with the damping

expected from the Liftech isolation concept. Achieving this amount of movement with the isolator is practical.

## Conclusions

Container cranes may be vulnerable to strong seismic motions. The seismic criteria for cranes are often more lenient than the criteria for wharves. This may result in wharves that are “operational” after a seismic event with container cranes that are not operational.

New cranes should be designed to criteria that are consistent with criteria used for the wharf design. The incremental cost of the cranes will be small and disruption to wharf operations after a seismic event will be decreased.

The seismic performance of existing cranes can be evaluated using conventional building analysis methods and criteria, with some exceptions. Local buckling may occur. It is usually not cost-effective to avoid localized damage and deformations. For many cranes, a minor retrofit may significantly improve the cranes seismic performance and reliability.

## References

Galambos, Theodore V. ed. 1988. *Guide to Stability Design Criteria for Metal Structures*, 4<sup>th</sup> Edition. New York, NY: John Wiley & Sons. ISBN: 0-471-09737-3.

*Seismic Design Guidelines for Piers and Wharves*, June 2006 draft. ASCE COPRI Committee on Seismic Design of Piers and Wharves.

Seismic Provisions for Structural Steel Buildings, *AISC Seismic Design Manual*, ANSI/AISC 341-05. Chicago, IL: American Institute of Steel Construction, Inc., March 9, 2005. ISBN: 1-56424-056-8.

Specifications for Structural Steel Buildings, *AISC Steel Construction Manual*, Thirteenth Edition. Chicago, IL: American Institute of Steel Construction, Inc., March 9, 2005. ISBN: 1-56424-055-X.