

Liftech Standard Structural Details

Copyright ©1995, 2000, 2005 Liftech Consultants Inc.

This document has been prepared in accordance with recognized engineering principles and is intended for use only by competent persons who, by education, experience, and expert knowledge, are qualified to understand the limitations of the data.

Permission to use, copy, and distribute this document is hereby granted for private, non-commercial, and educational purposes only, provided that the above copyright notice appears. All other rights reserved.

The publication of the information is not intended as a representation or warranty by Liftech Consultants Inc. Anyone making use of the information assumes all liability arising from such use.

Structural Details

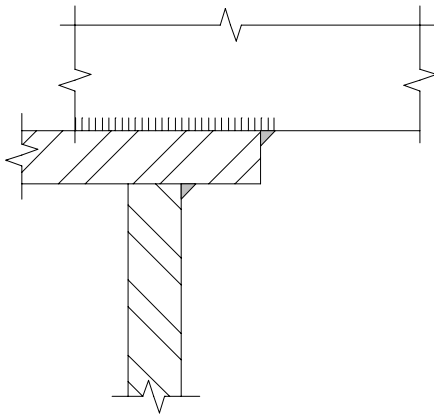

Not Acceptable

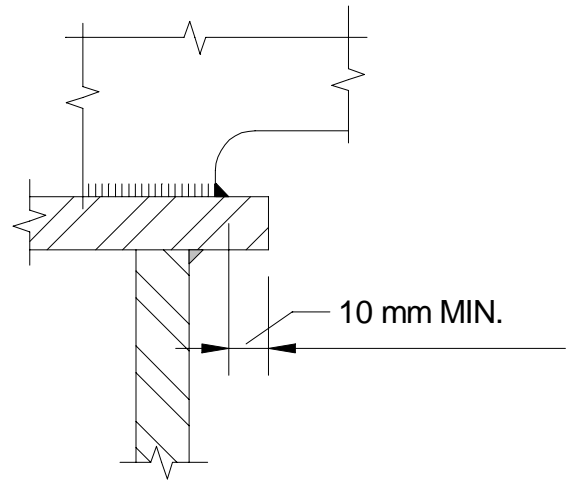

Acceptable

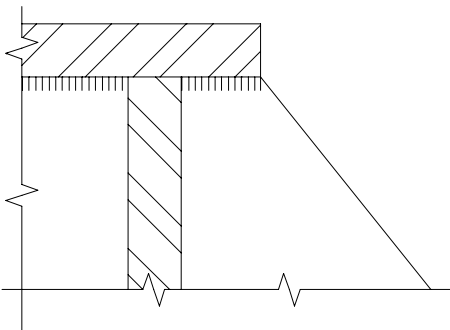

Not Acceptable

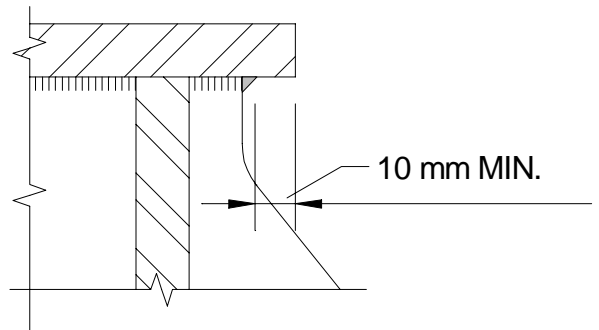

Acceptable

Structural Details

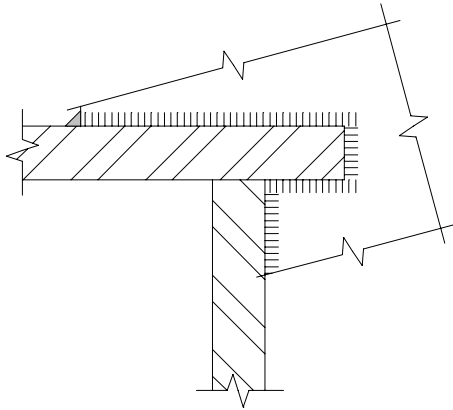

Not Acceptable

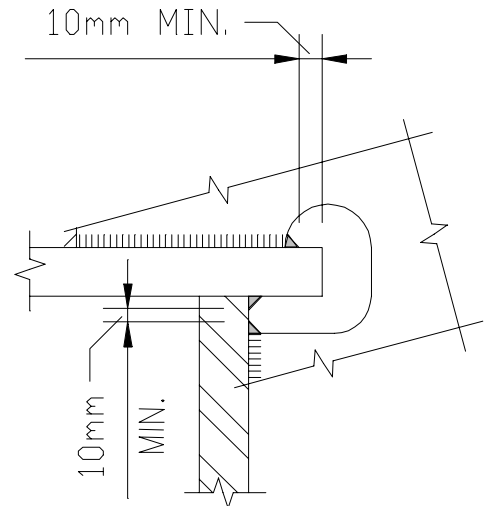

Acceptable

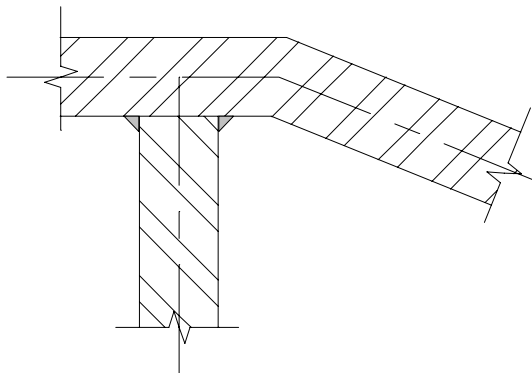

Not Acceptable

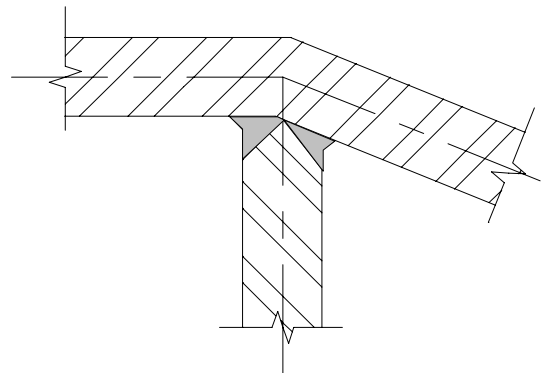

Acceptable

Structural Details

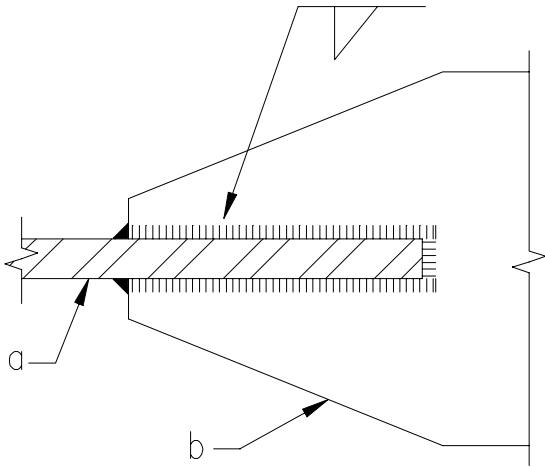

PLATE b SLOTTED

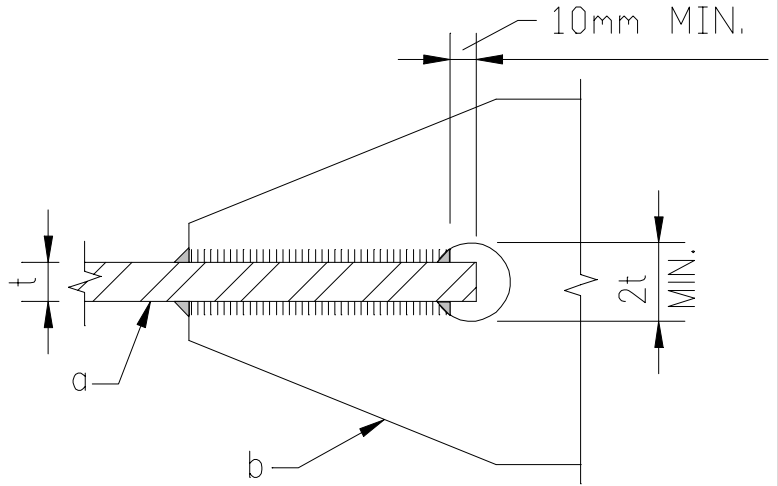
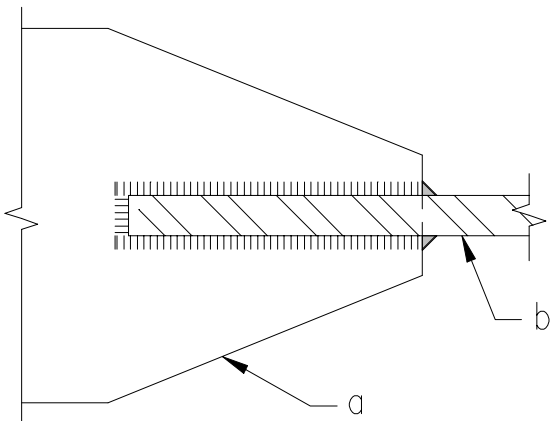
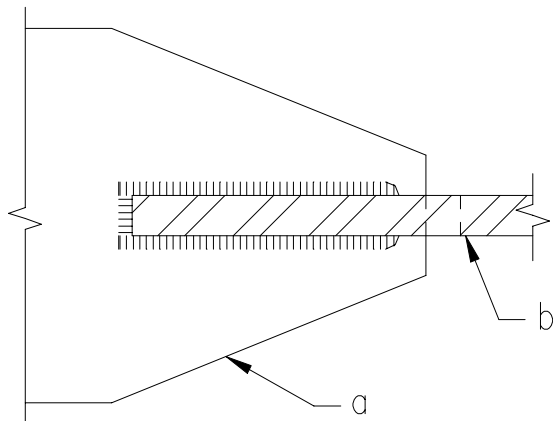

PLATE b SLOTTED



Not Acceptable



Acceptable

Structural Details

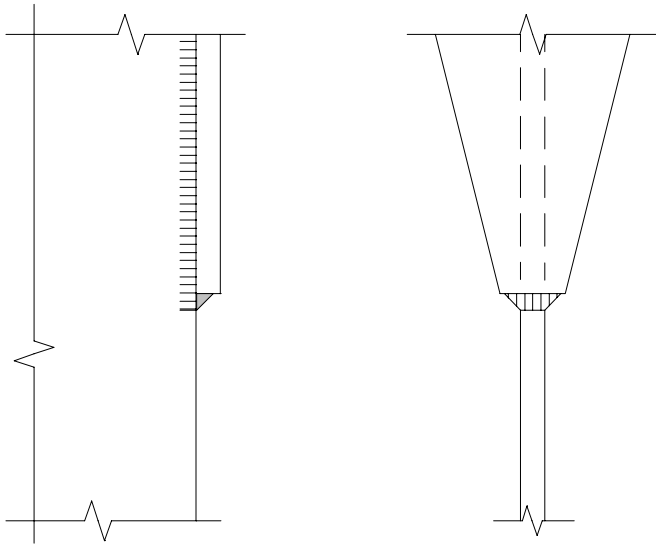

Not Acceptable

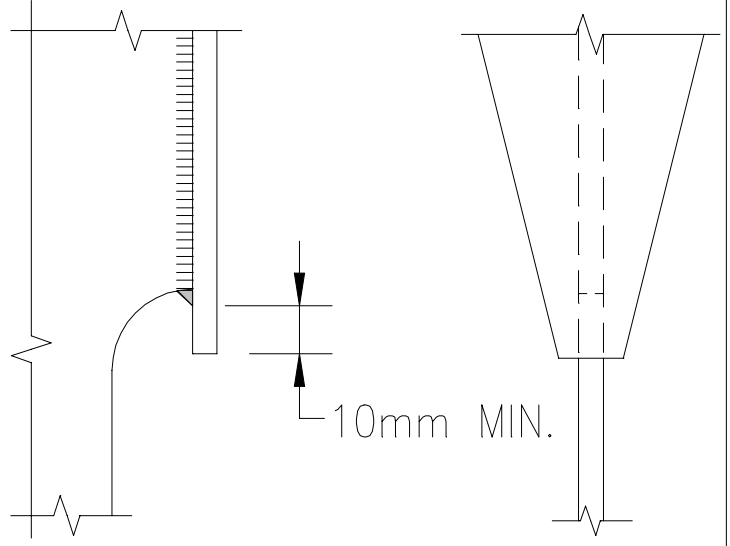

Acceptable

Structural Details

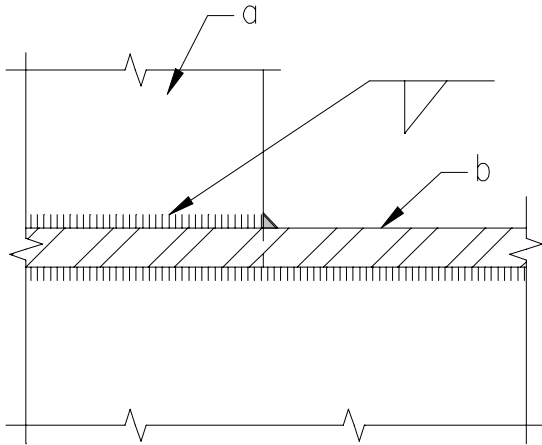

PLATE b SLOTTED

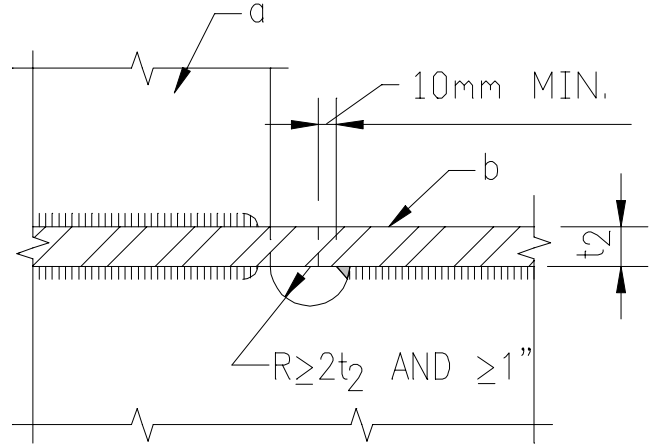
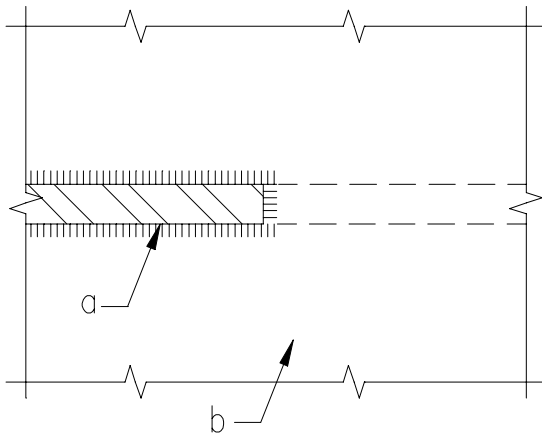
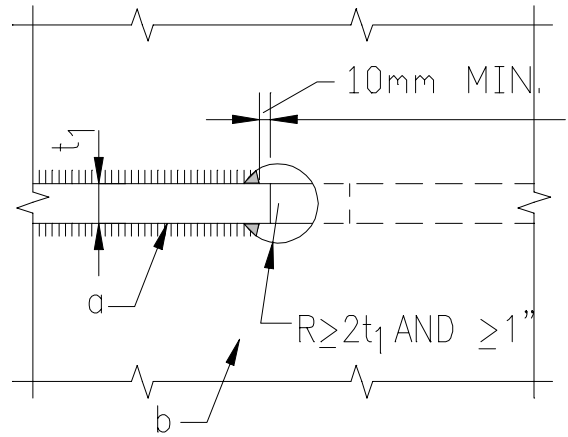

PLATE b SLOTTED



Not Acceptable



Acceptable

N:\Papers & Presentations\Working\StandardStructuralDetails\StructDet1-6.vsd

Structural Details

**Avoidance of Wraparound Weld
Acceptable**

See Sht. S7 for isometric view.

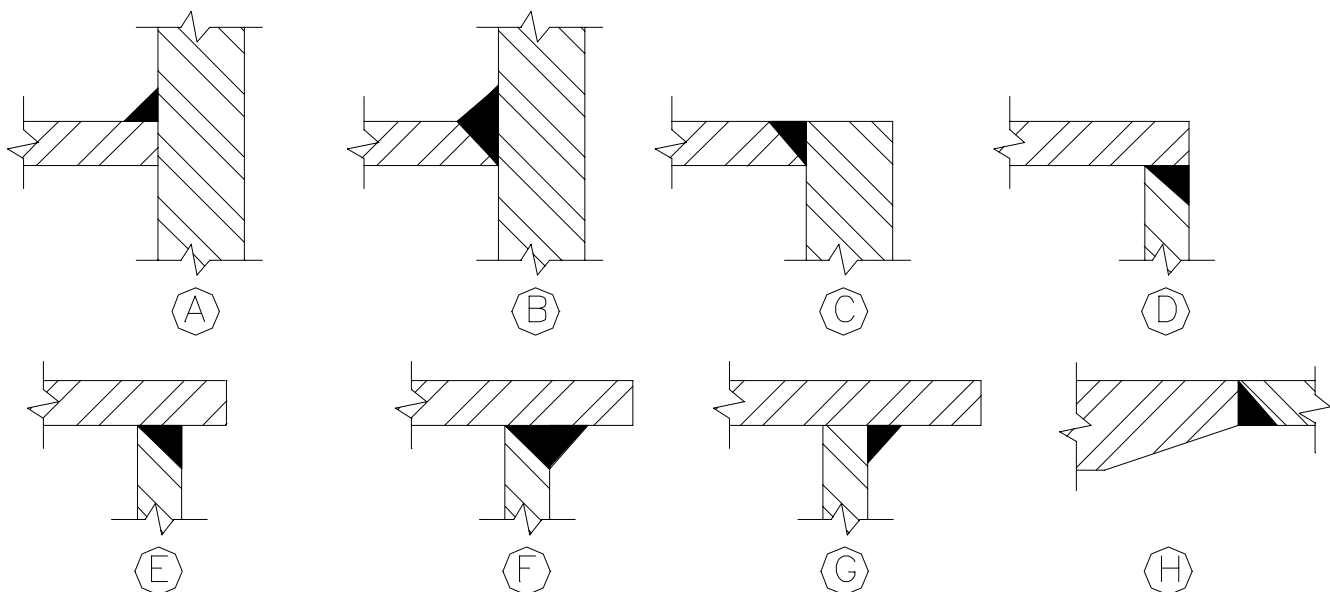
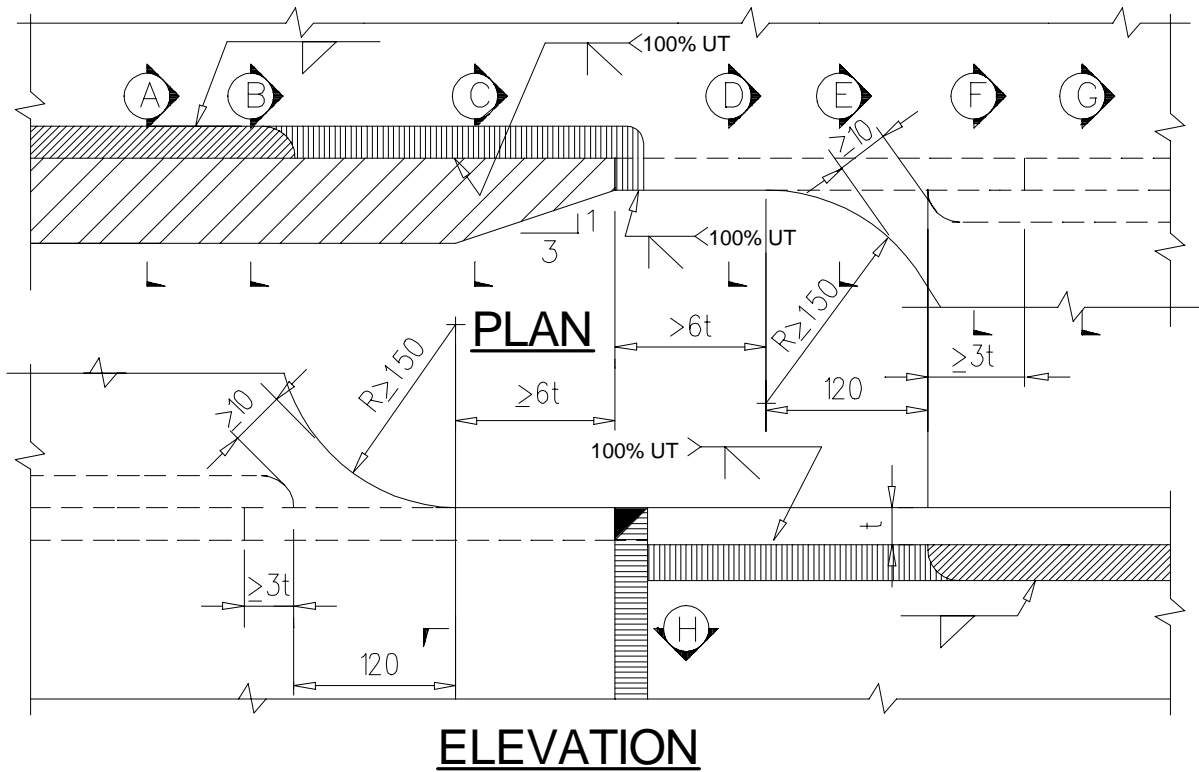

Note: Welds shall conform to the most recent edition of AWS D1.1, including the requirements for cyclically loaded structures.

Structural Details

Continued from Sht. S6.

Avoidance of Wraparound Weld
Acceptable

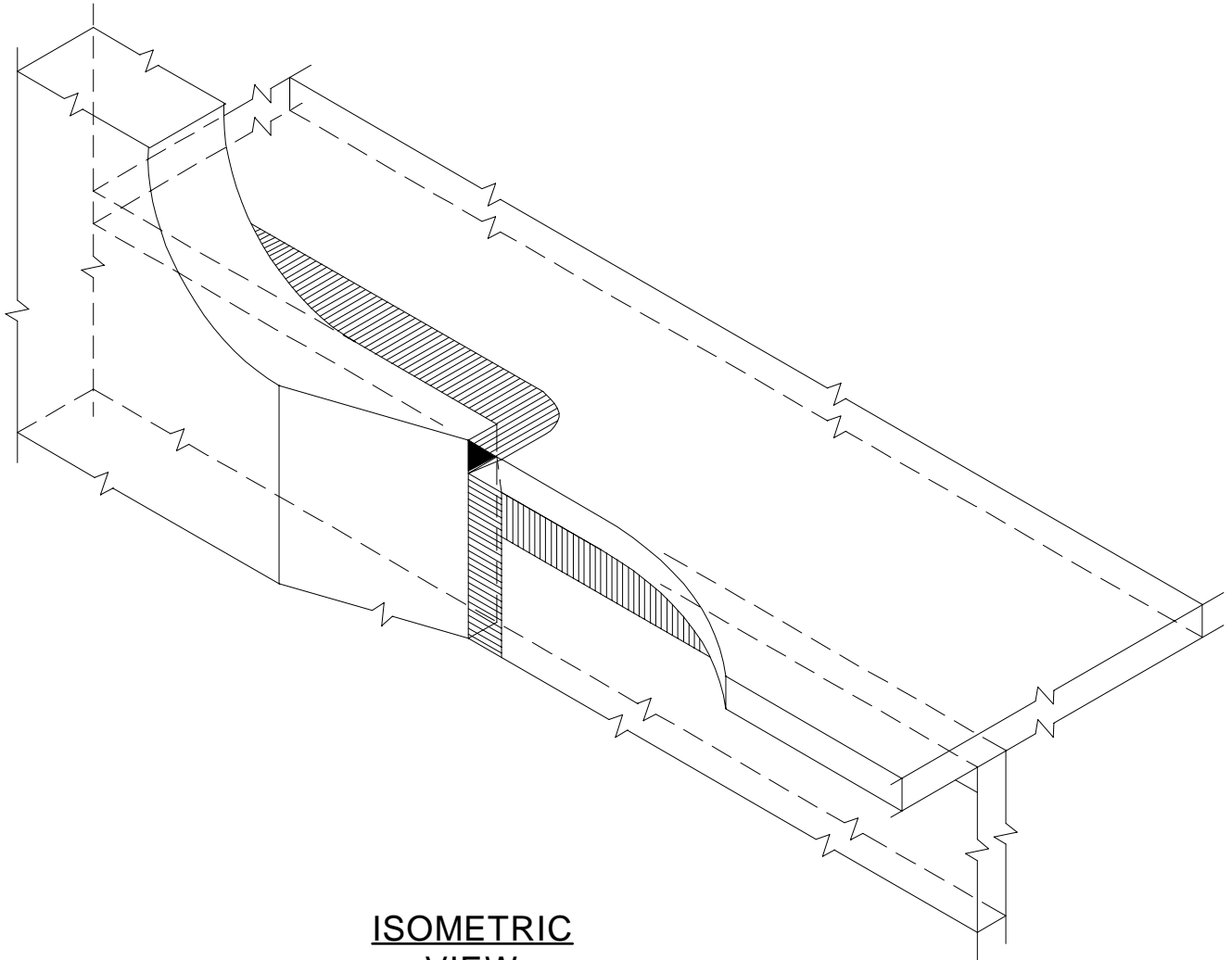

ISOMETRIC
VIEW

Structural Details

See Sht. S9 for Isometric View

Avoidance of Wraparound Weld
Acceptable

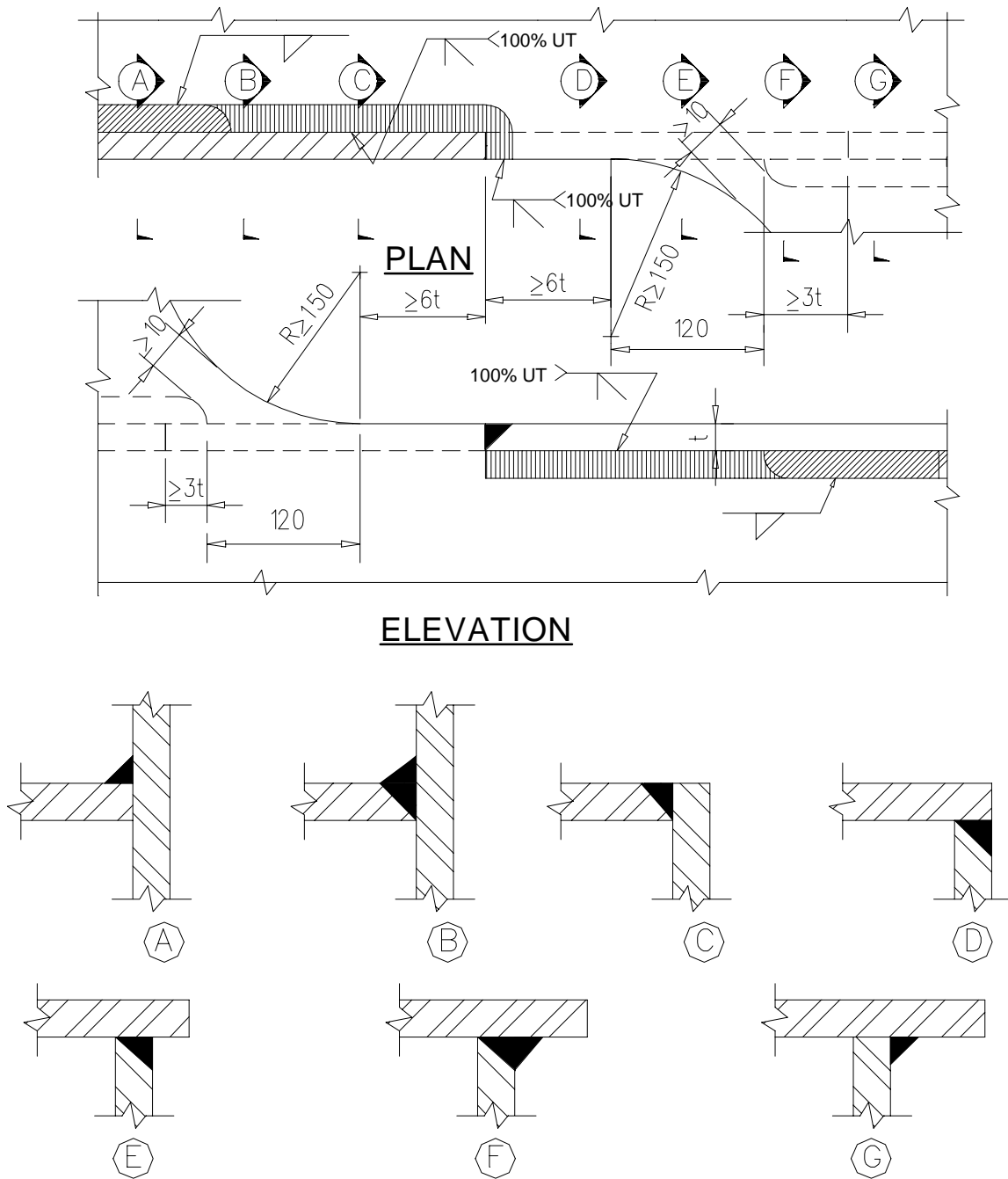

Note: Welds shall conform to the most recent edition of AWS D1.1, including the requirements for cyclically loaded structures.

Structural Details

Continued from Sht. S8.

Avoidance of Wraparound Weld
Acceptable

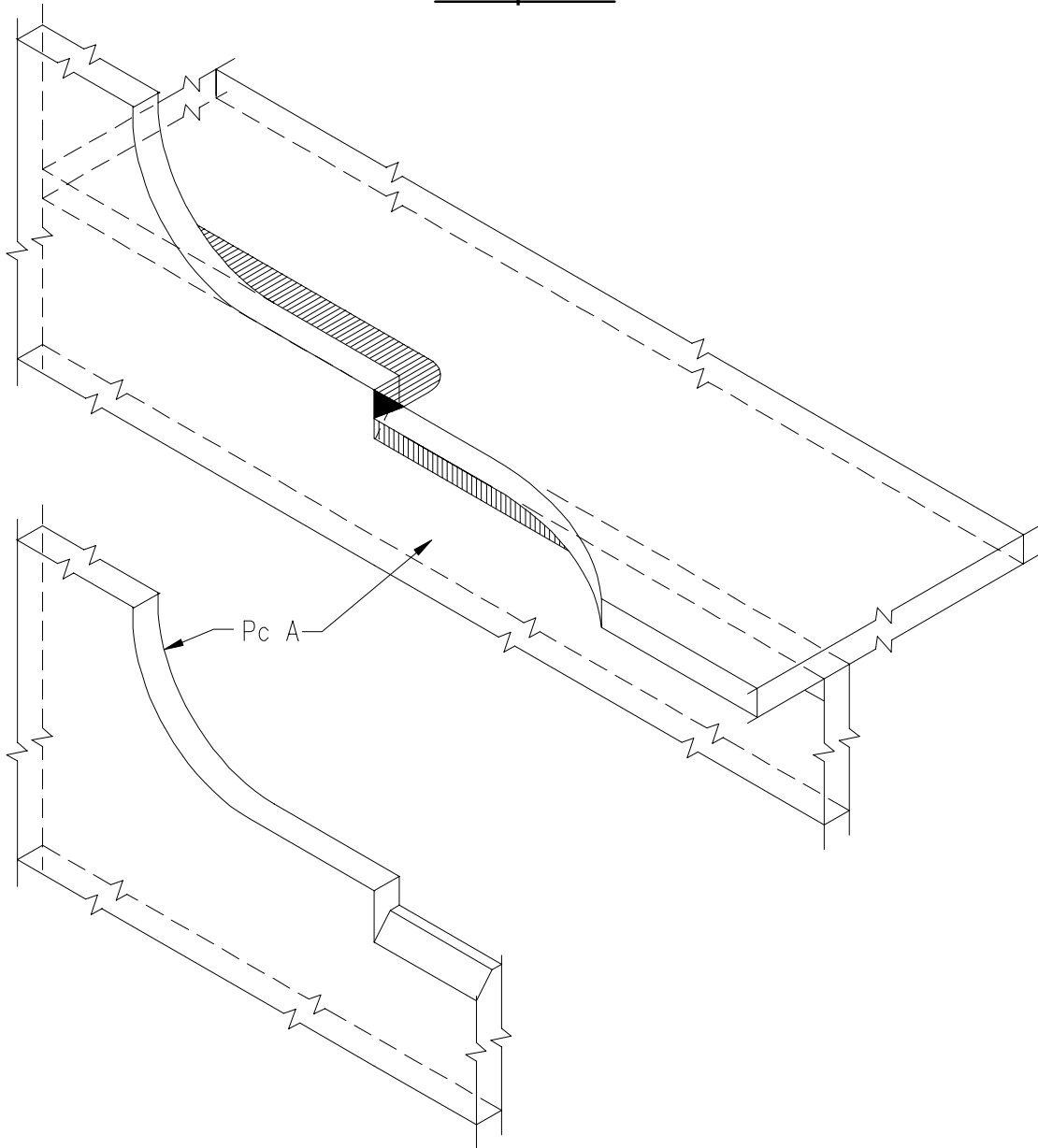

ISOMETRIC VIEW

Structural Details**Cruciform Weld**

FOR COMPONENTS
CARRYING CALCULATED
AXIAL STRESS

FOR FCMS: THE THROUGH
THICKNESS, YIELD, DUCTILITY, AND
CVN PROPERTIES SHALL COMPLY
WITH THE REQUIREMENTS FOR IN
PLANE TENSION PLATES.

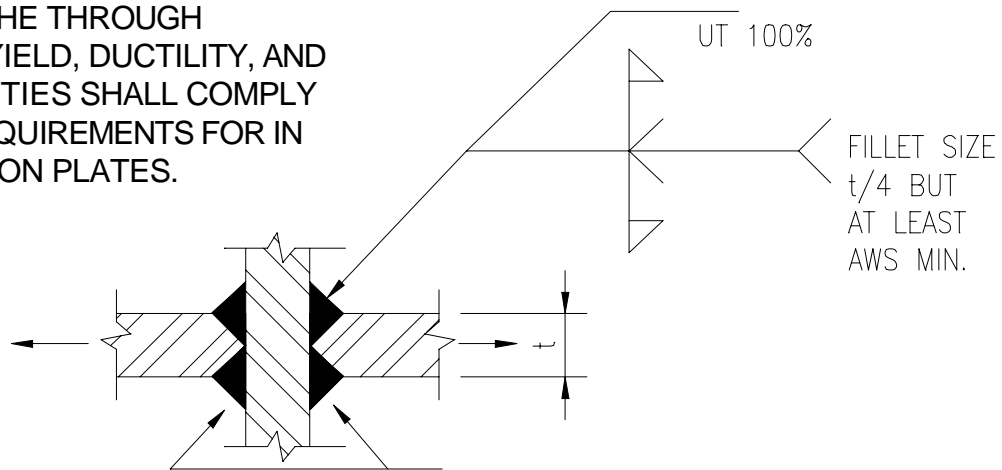

U.T. TO CHECK FOR LAMELLAR TEARS
BEFORE WELDING AND 36 HOURS
AFTER WELDING.

Eccentric Lap Joints

ECCENTRIC LAP JOINTS
BOLTED OR WELDED
ARE NOT ACCEPTABLE
ON COMPONENTS CARRYING
CALCULATED AXIAL STRESS.

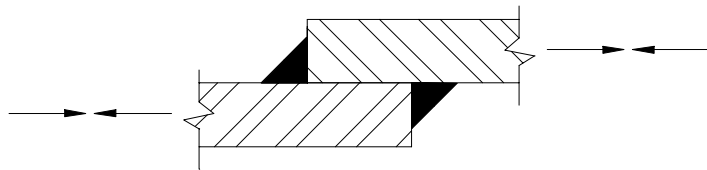

NOT ACCEPTABLE

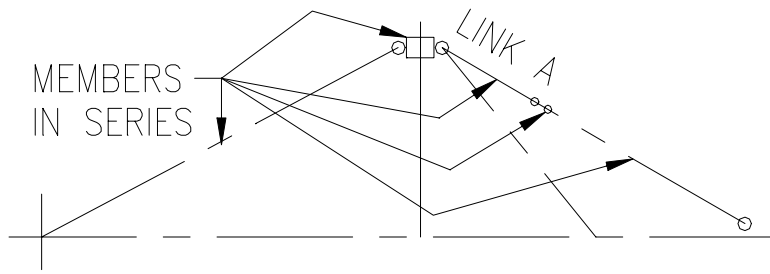

**Structural Details
Members in Series**

RELIABILITY OF SYSTEM SHALL BE CALCULATED BY DETERMINING THE RELIABILITY "D" OF EACH LINK INCLUDING ALL CONNECTION DETAILS, AND CALCULATING THE RELIABILITY OF THE SYSTEM USING:

$$D_{SYSTEM} = D_A \times D_B \times D_C \dots D_N$$

FOR EXAMPLE, THE RELIABILITY OF LINK A IS
 $D = D_1 \times D_2 \times D_3 \times D_4 \times D_5 \times D_6 \times D_7 \times D_8$
 THE VALUES OF D_i ARE FOUND FROM TABLE FOR EACH R_i .

TYPICAL FORESTAY EXAMPLES

NOTICE WHEN $R \leq 0.4$, $D = 1$
 AND WHEN THE CALCULATED STRESS RANGE IS $\leq 0.74 \times$ ALLOWABLE STRESS RANGE, $R \leq 0.4$.

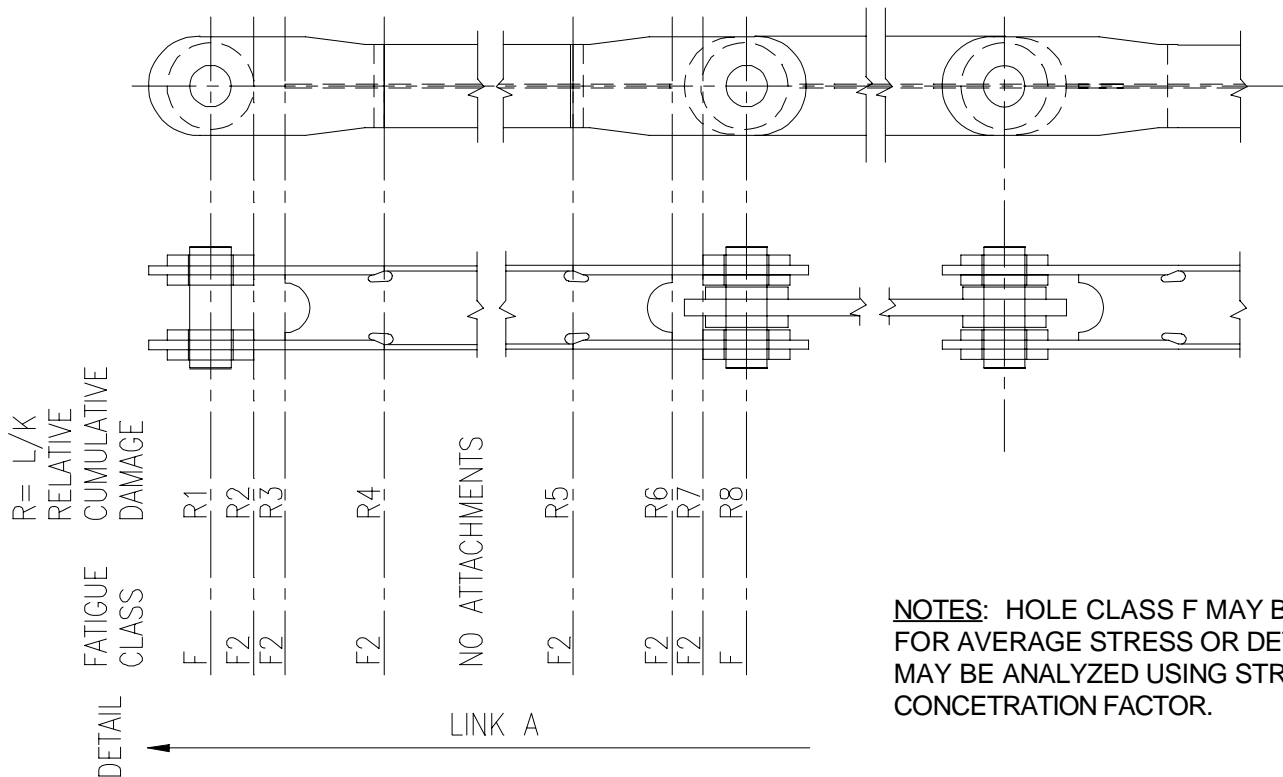

NOTES: HOLE CLASS F MAY BE USED FOR AVERAGE STRESS OR DETAIL MAY BE ANALYZED USING STRESS CONCENTRATION FACTOR.